

ANODE LINE= 72 OHM (see APPCAD freeware)  
 CAVITY INSIDE DIM ARE 308 X 308 ALUMINIUM AG3 THK 3mm

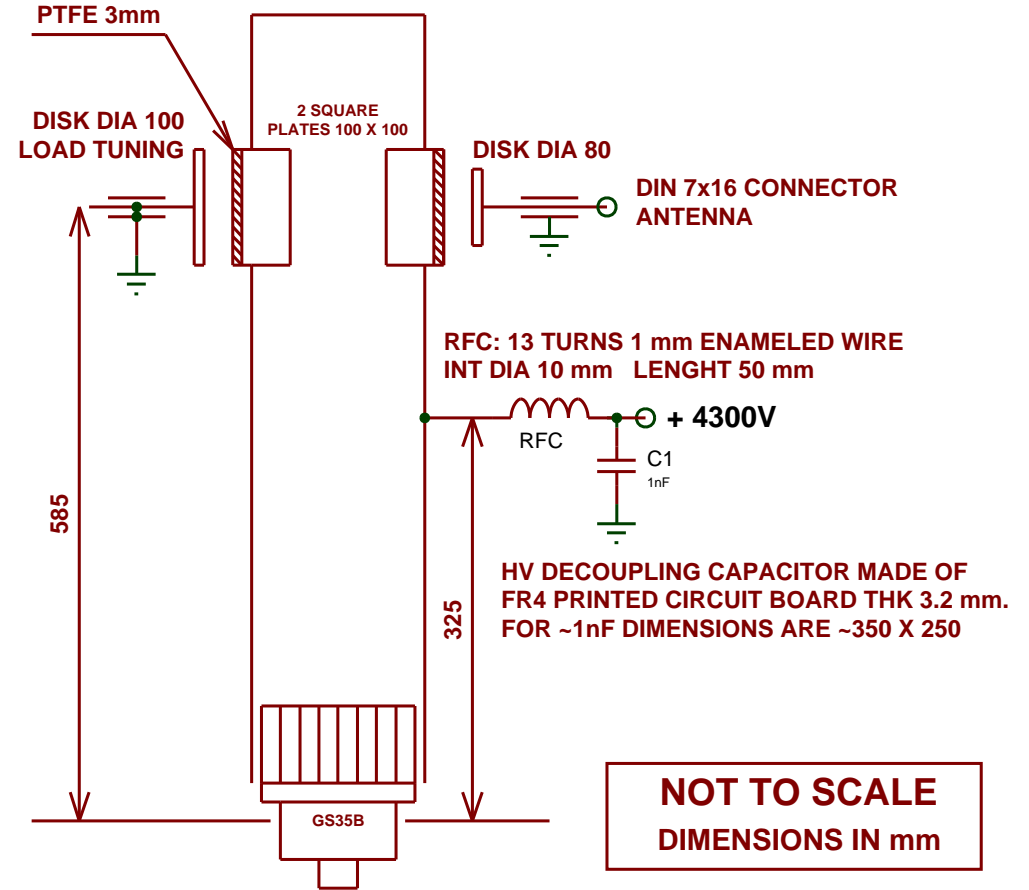

SEE PA3CSG WEBSITE FOR PICTURES  
[GS35 amplifier for 144 MHz](#)

**F1CXX 144 MHz/2.5KW PA GS35B CAVITY DIMENSIONS**