

# AN ANTENNA SWITCHING TECHNIQUE

## A PREAMPLIFIER FOR 144 MHz EME



DIVISION OF VARIAN

301 Industrial Way  
San Carlos, California



## AN EME ANTENNA RELAY AND SWITCHING TECHNIQUE

by Joe Reisert, W6FZJ/1

### Introduction:

EME operation requires careful attention to antenna relays and station switching. This becomes more apparent when we consider that typical transmitter output powers are 500 to 800 watts (+67 to +69 dBm). A further problem is the low noise preamps which will typically experience degraded noise figure and/or destruction when subjected to RF levels exceeding 100 mW (+20 dBm). For safe operation, we need at least 47 dB of isolation between the antenna and the preamp while in the transmitting mode. However, all is not lost. There are several solutions to this problem. Some of them will be discussed in this writeup.

### General Considerations:

Most EME stations use antenna mounted preamps. Therefore, antenna mounted relays are recommended. This helps part of the problem since the transmitter power at the antenna is typically 0.5 to 2 dB less than at the transmitter output. At amateur power levels, we are rapidly approaching the maximum recommended power levels for UHF, BNC and N coaxial connectors so every little bit helps. Therefore, select an antenna relay with adequate power handling capability.

Low noise preamps are more susceptible to burnout than ordinary preamps since the typical devices used are smaller (lower power) and have lower breakdown voltages. Furthermore, these devices usually have higher gains and, therefore, are more susceptible to oscillation when the antenna is removed. The simplest solution to this problem is to use a separate relay on the preamp (in addition to the antenna relay) which switches its input to a load resistor (typically 50 ohms) whenever the preamp is not in the receive mode. Do not return the preamp to a short or open circuit while transmitting, since this will encourage self-destruction of the device. This additional relay does not have to be a high power type. When properly connected (see Figure 1) it will enhance isolation in the transmitting mode and hence lessen the isolation requirements of the antenna relay.

Another facet of this problem is actual relay switching time. Since no mechanical relay switches ~~instantaneously~~, there can exist a time when the transmitter power may be present on the line before the preamp is adequately isolated from the antenna. One effective way to handle this situation is to use a delay relay in the final power amplifier, preferably in the high voltage line. This will allow the antenna and preamp relays to switch before the transmitter power is applied to the antenna. In addition to protecting the preamp, this will lessen the chances of burning out the antenna relay.

### A Recommended EME Relay and Switching Scheme:

The proposed system (see figure 1) covers most of the situations discussed above and has several other advantages. Whenever the 28 volt supply is removed, the complete station is disconnected from the antenna and the preamp input is terminated in a load resistor. This enhances static, lightn-

ing and RF protection. An optional provision allows the preamp to be returned to the load when desired. This can greatly facilitate sun noise checks or local trouble shooting.

#### Relay Operation:

1. When the 28 volts is removed, the antenna is disconnected (floating) and the preamp is returned to a load for protection.

2. When the 28 volts is applied (such as when station power is turned on) the antenna is directly connected to the preamp.

3. When the station transmit/receive switch is switched to transmit:

a. the preamp is disconnected from the antenna and returned to a load,

b. the transmitter output is connected to the antenna,

c. the high voltage, after a short delay caused by RL4 & RL5, is connected to the power amplifier.

4. When the transmit/receive switch is returned to the receive mode, high voltage is rapidly removed from the transmitter power amplifier and the antenna is returned to the preamp restoring the receive mode.

5. If the N.C. pushbutton switch (SW1 - optional feature) is depressed, the preamp is returned to a load for sun noise check or trouble shooting.

#### Recommended Components:

RL1 - A 28VDC coaxial high power relay with low VSWR and low loss, preferably with type N or equivalent connectors and N.O. (normally open) contact. A suitable type is the TRANSCO type "Y" with N.O. contacts, frequently available on the surplus market. If not available, either an Amphe-nol/FXR type 320-10931-3 or Dow Key type DK-60 with type N connectors and special "high isolation" receiver connectors can be used. The latter two relays are N.C. (normally closed) types so if used, the N.C. side should go to the transmitter output. This will only afford protection to the preamp when station power is removed. All other operation will remain normal. If RL2 is not used, make sure that the isolation of RL1 is at least 47 - 50 dB in the transmit mode. Remember that isolation goes down with increasing frequency. The Dow Key relay is marginal, at best, at 432 MHz and completely unsuitable above 450 MHz while the Transco is useable to 12 GHz.

RL2 - This relay can be similar to RL1 if desired. However, the only requirements for this relay are good VSWR, low loss and moderate (20 - 30 dB minimum) isolation. Suitable types are available on the surplus market such as Transco, Teledyne, RLC, etc. An inexpensive BNC type that is readily available on surplus should be suitable up to 225 MHz.

RL3 - Any ordinary 28 volt SPDT relay, such as Potter and Blumfield, etc.

RL4 - Same as RL3 except DPDT.

RL5 - Preferably a high voltage type, such as a vacuum relay. The

Jennings RF1D (or equivalent) is recommended.

SW1 - An N.C. pushbutton switch (optional).

R1 - A low VSWR termination (usually 50 ohms).

Summary:

Any or all of the above circuitry may be used for EME work, or even on a conventional station. It has served me well on my EME station and allows quick and safe operation when echo testing. It also gives me some peace-of-mind when the station is not in operation.

One last thought; don't skimp on the price and performance of RL1. A shortcut here may cause the loss of an expensive low noise preamplifier or the relay itself. This will more than offset the savings of a less than adequate relay.

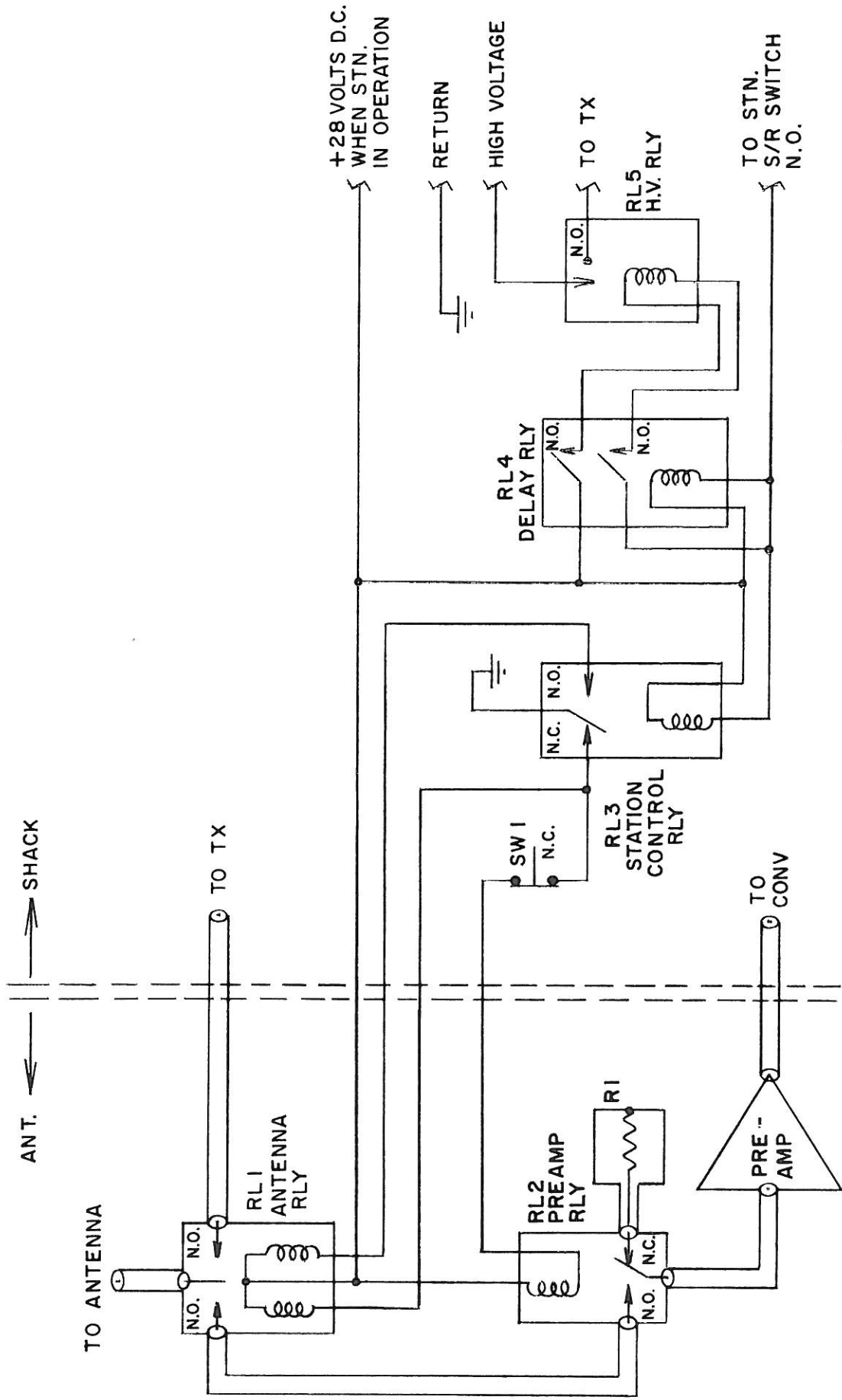
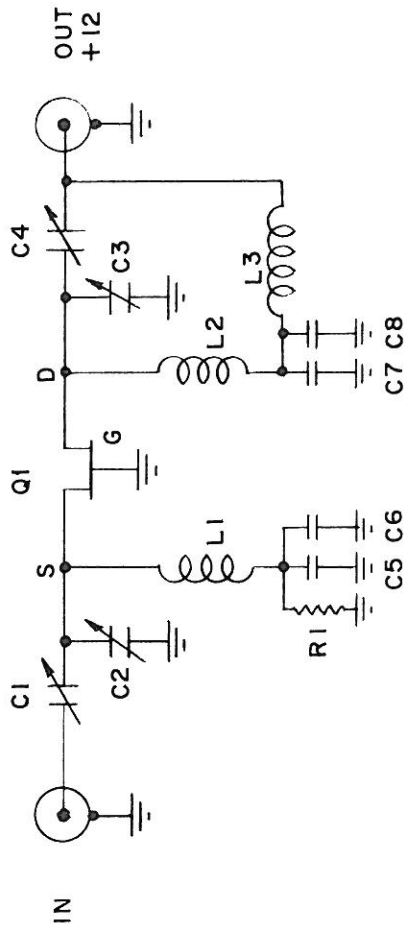
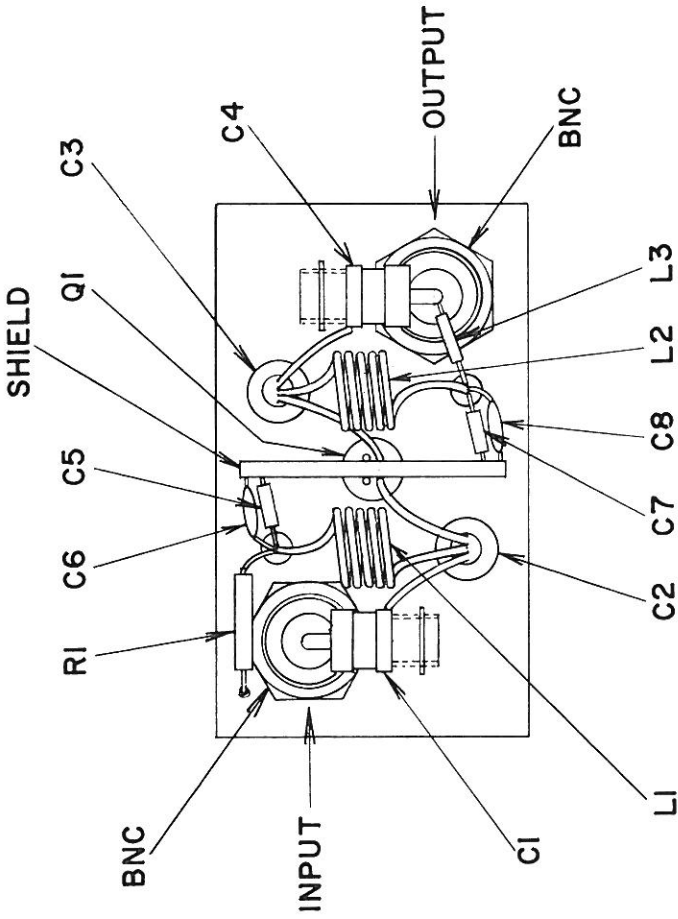
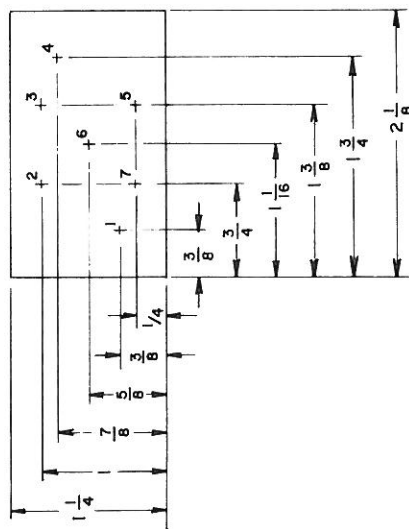

FIG. 1 - EME ANTENNA RELAY & SWITCHING SCHEME



- L1, L2 - 5T #18 BARE COPPER WIRE  
1/4" I.D.
- C1, C2, C3, C4 - JOHANSON .5-10 pf
- C5, C7 - 500 pf disc
- C6, C8 - .01 disc
- R1 - CHOSEN FOR DRAIN CURRENT OF 10 Ma.
- Q1 - SILICONIX U310 OR 2N5397
- L3 - 1μhy



- # 1 & 4 - 3/8" DRILL - BNC CONNECTORS
- # 2 & 5 - # 1 DRILL - JOHANSON CAPACITORS
- # 3 & 7 - # 27 DRILL - TEFLON STANDOFF
- # 6 - HOLE FOR SOCKET
- MATERIAL - 1/16 DOUBLE SIDED P.C. BOARD
- BOX - POMONA 2417

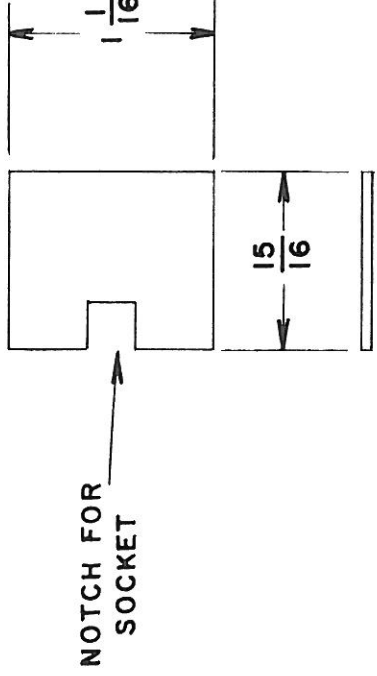

MATERIAL - 1/16 DOUBLE SIDED P.C. BOARD

Figure 2

A low noise JFET preamplifier recommended by W2AZL for 144 MHz moonbounce communication.

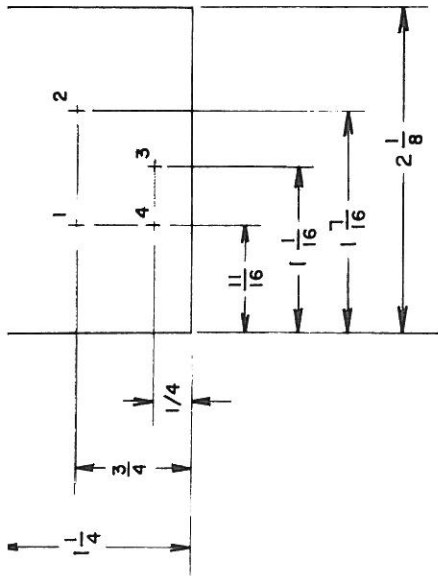

- # 1 & 2 -  $3/8$ " DRILL - BNC CONNECTORS
- # 3 - HOLE FOR FEED THRU CAPACITOR C2
- # 4 - # 32 DRILL - # 4-40UNC - Grd. SOLDER LUG

MATERIAL -  $1/16$  DOUBLE SIDED P.C. BOARD  
 BOX - POMONA 2417

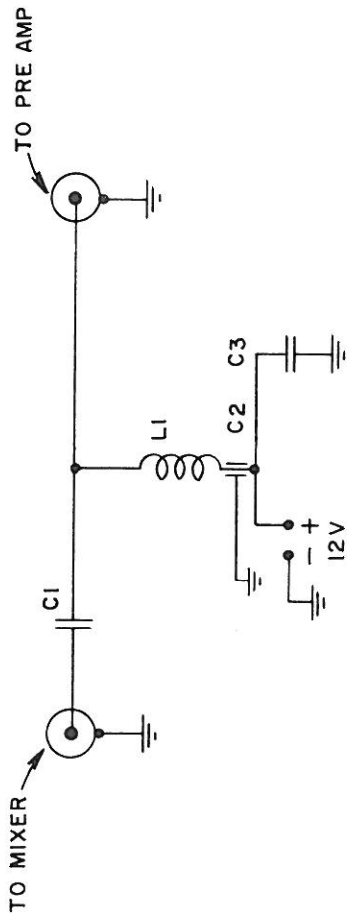

- C1 - 500 pf disc
- C2 - 500 pf FEED THRU
- C3 - .01 disc
- L1 - 1μhy

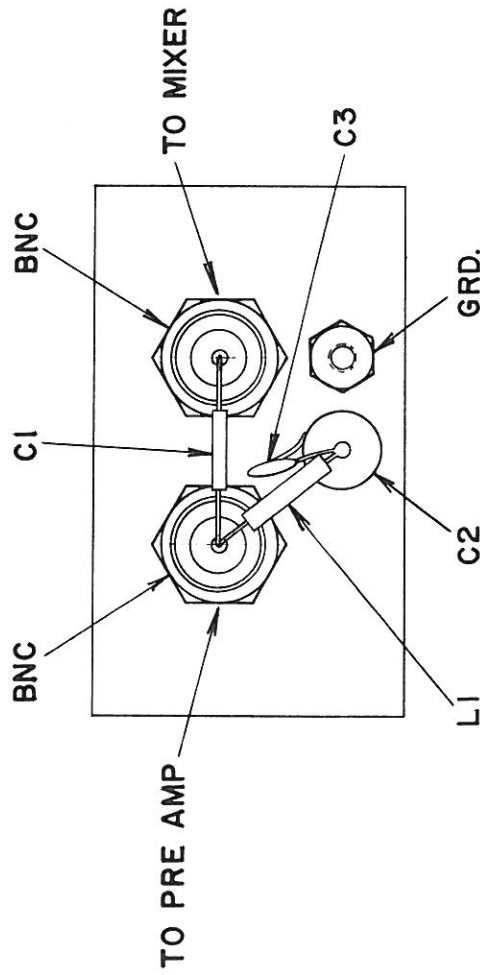

Figure 3

A circuit that can be used in conjunction with the preamplifier to allow the +12 volts to be fed to the antenna mounted preamplifier using the center conductor of the coaxial cable connecting the preamplifier to the converter at the operating position.



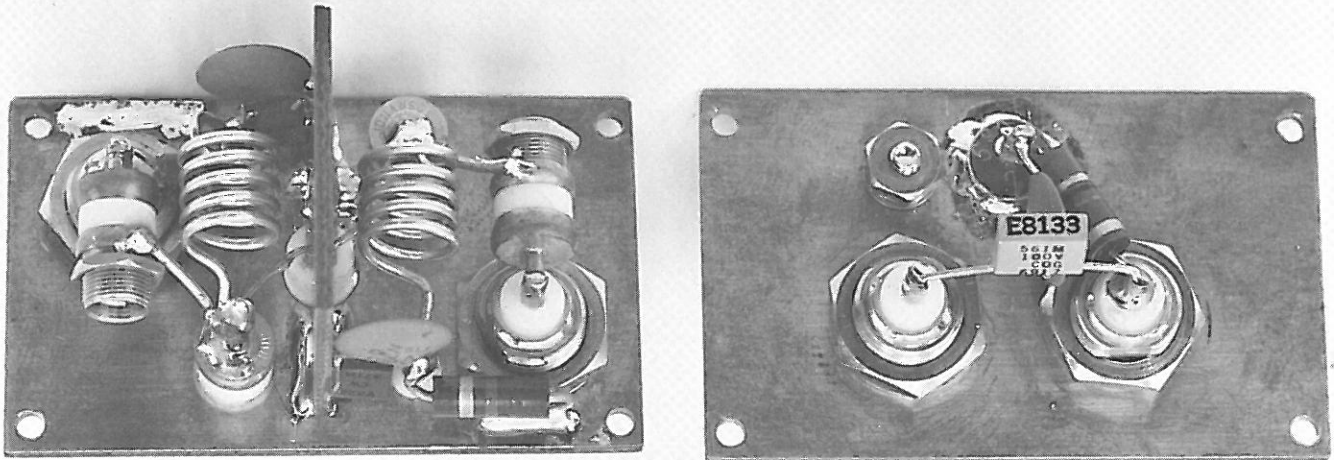
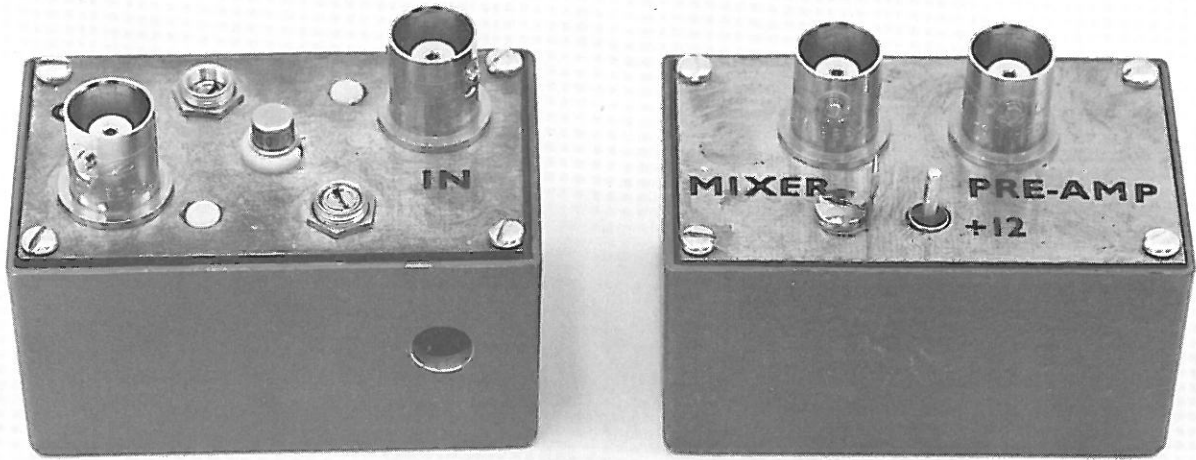

Figure 4

Photograph of the two circuits as built by W6PO. The preamplifier ahead of a low noise converter provides a noise figure of 1.3 dB.





